

Mini Racing Boat Series

User Manual

For 795/797 Brushed Series
V 04.2024

WARNING

The following terms are used throughout the product literature to indicate various levels of potential harm when operating this product:

NOTICE: Procedures, which if not be properly followed, will create a possibility of physical property damage AND or possibility of injury.

WARNING: Read the **ENTIRE** instruction manual to become familiar with the features of the product before operating. Fail to operate the product correctly can result in damage to the product, personal property and cause serious injury.

This is a sophisticated hobby product. It must be operated with caution and common sense and requires some basic mechanical ability. Fail to operate this product in a safe and responsible manner could result in injury or damage to the product or other property. This product is not intended for use by children without direct adult supervision. Do not use with incompatible components or alter this product in any way outside of the instructions provided by VolantexRC Co.,Ltd.. This manual contains instructions for safety, operation and maintenance. It is essential to read and follow all the instructions and warnings in the manual, prior to assembly, setup or use, in order to operate correctly and avoid damage or serious injury.

AGE RECOMMENDATION: NOT FOR CHILDREN UNDER 14 YEARS. THIS IS NOT A TOY.

Safety Precautions and Warnings

As the user of this product, you are solely responsible for operating in a manner that does not endanger yourself and others or result in damage to the product or the property of others.

- Always keep a safe distance in all directions around your boat to avoid collisions or injury. This boat is controlled by a radio signal subject to interference from many sources outside your control. Interference can cause momentary loss of control.
- Always operate your boat in open spaces away from full-size vehicles, traffic and people.
- Always carefully follow the directions and warnings for this and any optional support equipment(chargers, rechargeable battery packs etc.).
- Always keep all chemicals, small parts and anything electrical out of the reach of children.
- Always avoid water exposure to all equipment not specially designed and protected for this purpose.

Moisture causes damage to electronics.

- Never place any portion of the boat in your mouth as it could cause serious injury or even death.
- Never operate your boat with low transmitter batteries.
- Always keep your boat in sight and under control.
- Always use fully charged batteries.
- Always keep transmitter powered on while boat is powered.
- Always remove batteries before disassembly to avoid touching throttle and cause damage.
- Always keep moving parts clean.
- Always keep parts dry.
- Always let parts cool after using before touching.
- Always remove batteries after usage.
- Always ensure failsafe is properly set before running.
- Never operate a boat with damaged wiring.

Battery and Charging Warnings

CAUTION: All instructions and warnings must be followed exactly. Mishandling of Li-Po/Li-Ion/Ni-Mh batteries can result in fire, personal injury, and/or property damage.

- The battery charger included with your boat is designed to safely balance and charge the specific Li-Po/Li-Ion/Ni-Mh battery.
- By handling, charging or using the included battery, you shall assume all risks associated with Li-Po/Li-Ion/Ni-Mh battery.
- If at any time the battery begins to balloon or swell, discontinue use immediately. If charging or discharging, you should discontinue and disconnect. Continue to use, charge or discharge a battery that is ballooning or swelling can result in fire.
- Always store the battery at room temperature in a dry area for best results.
- Always transport or temporarily store the battery in a temperature range of 40-120 Fahrenheit degrees (5-49 degrees centigrade). Do not store battery or your boat in a car or direct sunlight. If stored in a hot car, the battery can be damaged or even cause fire.
- Always charge a battery away from flammable materials.
- Always inspect the battery before charging and never charge damaged batteries.
- Always disconnect the battery after charging, and allow the charger cool before next charge.
- Always constantly monitor the temperature of the battery pack while charging.
- **ONLY USE A CHARGER SPECIALLY DESIGNED TO CHARGE SPECIFIC BATTERIES.**
- Never discharge Li-Po cells till below 3V under load.
- Never cover warning labels with hook or loop strips.
- Never leave charging batteries unattended.
- Never charge batteries outside recommended levels.
- Never attempt to dismantle or alter the charger.
- Never allow minors to charge battery packs.
- Never charge batteries in extremely hot or cold places (recommended between 40-120 Fahrenheit degrees / 5-49 degrees centigrade) or in direct sunlight.

Box Contents

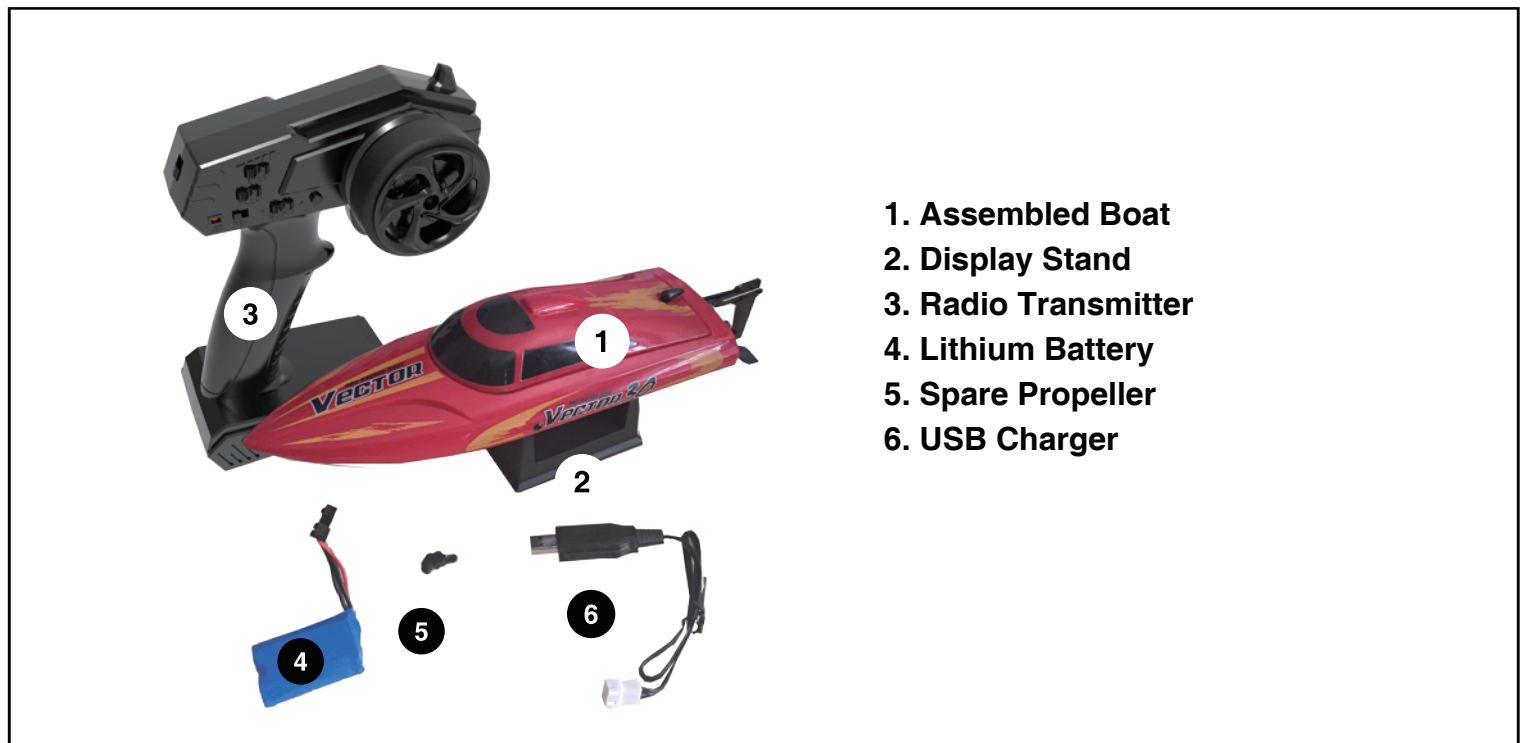

Note: The Photo shown as an example for all mini racing boat series. The actual product may vary slightly from manual according to the model you purchased.

Boat Batteries Installation

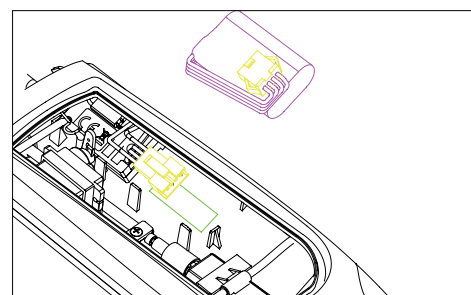
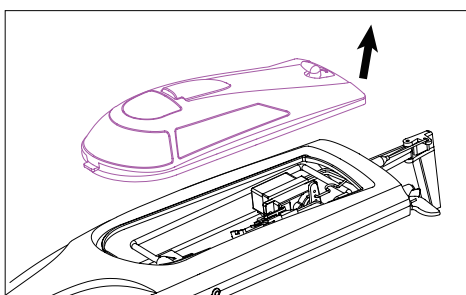
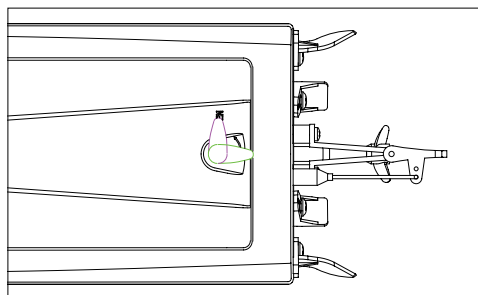

1. Rotate the hatch of the hull cover by clockwise to unlock the hatch.
2. Open the hull cover.
3. Adhere included hook tape to the battery.
4. Secure the battery to the hook tape in the boat.

Check Radio System

CAUTION: Always keep all body parts, hair and dangling or loose items away from a spinning propeller, as these can be entangled.

NOTICE: Always power on the transmitter before powering on the ESC. Always power off the ESC before powering off the transmitter. Never transport the boat with the battery connected to the ESC.

1. Turn the transmitter throttle and rudder trim to the middle position.
2. Power on the transmitter.
3. Connect a fully charged battery to the ESC.
4. Ensure the rudder moves in the proper direction when the controller is moved left or right.
5. Pull the throttle to max power position, then return the throttle to min power position, ensuring the propeller turns counterclockwise. The ESC auto-sensing voltage cutoff function will engage when the ESC detects a low battery charge. Release the throttle and recharge the battery when necessary.

NOTICE: Read completely the radio appendix for more detailed instruction of using the radio. Make sure you have totally studied the radio manual appendix before you really start operating the boat with the radio.

Getting Started

1. Power on the transmitter.
2. Connect a fully charged battery.
3. Test the transmitter's control of the boat with the boat on the display stand.
4. After launching the boat in the water, start driving slowly. If the boat does not go straight, adjust the trimmer on the transmitter to run it straight.
5. Power off the ESC and disconnect the battery packs.
6. Always turn off transmitter at last.
7. Allow the motor, ESC and battery packs to cool before charging the battery or operating the boat again.

WARNING: DO NOT TURN OFF THE TRANSMITTER BEFORE UNCONNECTING BATTERY OF RECEIVER, OR THE RECEIVER MAY PICK UP STRAY SIGNALS AND RUN OUT OF CONTROL TO CAUSE ACCIDENT!

NOTICE: Always store the boat with hatch removed to prevent mold and mildew growth inside the hull.

Test Your Boat in Water

1. Carefully place the boat in water.
2. Operate the boat at slow speed near the shoreline. Avoid objects in water at all time.
3. Once you are comfortable operating the boat at slow speed, make sure it is safe and then operate the boat farther from the shoreside.

Tip: If you are using too much steering trim on your transmitter to make the boat drive straight, return the trim to neutral and mechanically center the rudder. To do this, loosen the knob from the rudder horn, adjust the knob to a proper position linking to pushrod, make sure ruder is centered.

4. Bring the boat back when you notice it starts to run at low speed even when you pull up throttle to max.

Tips of Controlling

Keep away from watercraft, stationary objects, waves and other rapidly moving water, wildlife, floating debris or overhanging trees. You should be careful to avoid boating in areas where there are many people, such as swimming areas, park waterways or fishing areas. Consult local laws and ordinances before choosing a location to pilot your boat. maximum speeds are only achieved when the water conditions are smooth and there is little wind. A sharp turn, wind or waves can turn over a boat when it is moving quickly. Always control your boat for the wind and water conditions so that the boat does not turn over. When running your boat for the first time, we recommend calm wind and water conditions so that you can learn how the boat responds to your control. When making turns, decrease the throttle in order to decrease speed and probability of flipping the boat over.

NOTICE: When running at full speed in choppy waters, the propeller may exit and re-enter the water repeatedly and very quickly, subjecting the propeller to some stress. Frequent stress may damage the propeller.

CAUTION: Never retrieve your boat from the water in extreme temperatures, turbulence or without supervision.

Motor Care

Prolong motor life by preventing overheating conditions. Undue motor wear results from frequent turns, stops and starts, pushing object, boating in rough or vegetation and boating continuously at high speed.

Over-temperature protection is installed on the ESC to prevent circuit damage, but cannot protect the motor from pushing against heavy resistance.

When You Finish

1. Power off the ESC.
2. Disconnect the battery in hull.
3. Power off the transmitter.
4. Remove batteries from boat and transmitter.

NOTICE: Always store the boat without hatch covered or inner liner sealed. Otherwise moisture may cause mold and mildew to grow in the boat.

Maintenance

Always replace the shaft when it is damaged or shows visible wear or injury and property damage may result.

Lubricating the shaft is vital to the life of the drivetrain. The lubricant also acts as a water seal, keeping water from entering the hull through the stuffing box.

Lubricate the shaft, propeller shaft and all moving parts after every 2-3 hours of operation. Always replace parts that show visible wear or damage.

1. Loosen the water cooling tubes from the motor.
2. Loosen setscrew from the motor mount and remove the motor with the coupling out from hull.
Tips: Use paper or cloth to touch the shaft.
3. Loosen the propeller from the shaft as shown.
4. Remove the drive shaft by sliding it out of the stuffing box. Wipe lubricant and material from the shaft.
5. Lubricate the full length of the shaft assembly up the drive dog with marine grease.
6. Carefully reinstall the drive shaft, ensuring that there is a 1-2mm gap between the prop strut and the drive dog to allow for shaft shrinkage under load.

NOTICE: Running the boat in salt water could cause some parts to corrode. If you run the boat in salt water, rinse it thoroughly in fresh water after each use and lubricate the drive system.

NOTICE: Because of its corrosive effects, running RC boats in salt water is at the discretion of the user.

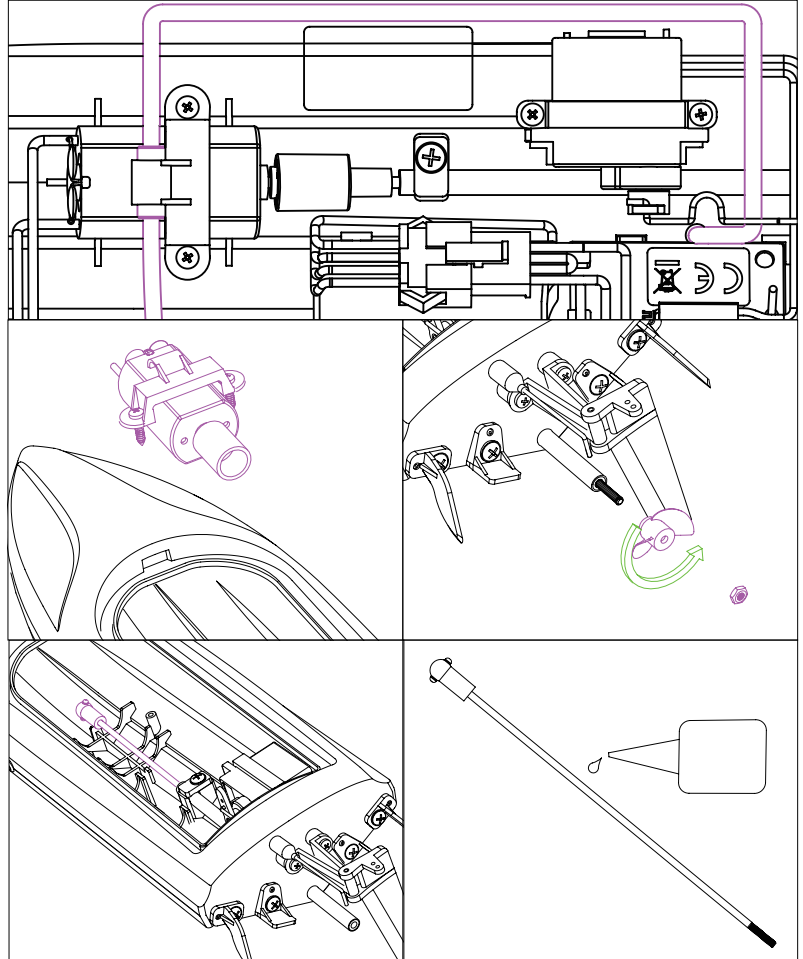

Check List

Before Boating

- Install fully charged batteries in your boat and transmitter.
- Connect the boat battery to ESC.
- Make sure the boat is bound to the transmitter (otherwise, bind the boat to the transmitter using the included binding instructions.)
- Make sure all linkages move freely on the boat.
- Ensure the motor mount is secured to the hull so that the motor stays steady.
- Perform a Control Direction Test with the transmitter.
- Adjust the steering rate on your transmitter as needed.
- Find a safe and open boating area.
- Plan a safe boating route for the water and wind conditions.

After Boating

- Always power off the receiver before powering off the transmitter to maintain control of the boat and to retain transmitter binding.
 - Disconnect the battery from the receiver and remove the batteries from the boat.
 - Fully dry the inside and outside of the boat, including the water cooling lines and jackets around the motor and ESC. Remove the hatch and radio box cover before storing your boat.
 - Repair any damage or wear to the boat.
 - Lubricate the shaft.
 - Make note of lessons learned from the trimming of your boat, including water and wind conditions.
- Tips: The hook and look strips in the boat retain water. To dry them press on them with a dry cloth.

Charging Instruction

For charging the included lithium battery, you can only use the included charger or a suitably compatible lithium battery charger.

Charging the lithium battery using a none lithium battery compatible charger (such as a NiCd or NiMH battery charger), or even a different lithium battery charger with the incorrect settings, may result in damage to the battery or even fire resulting in property damage and/or personal injury.

CAUTION: You must be careful to ensure proper polarity before making the connection.

Follow below steps to charge the lithium battery with the included charger.

For **USB charger** -

1. Power off your vehicle.
2. Carefully plug the charger into the USB port on your computer or USB adaptor.
3. Connect the battery into the charger.
4. While charging, the red LED charge indicator will be solid on. The charging process takes approximate 3.5 hours. For safety reasons, never charge the battery over 4 hours.
5. When the battery is fully charged, the LED charge indicator will be off.

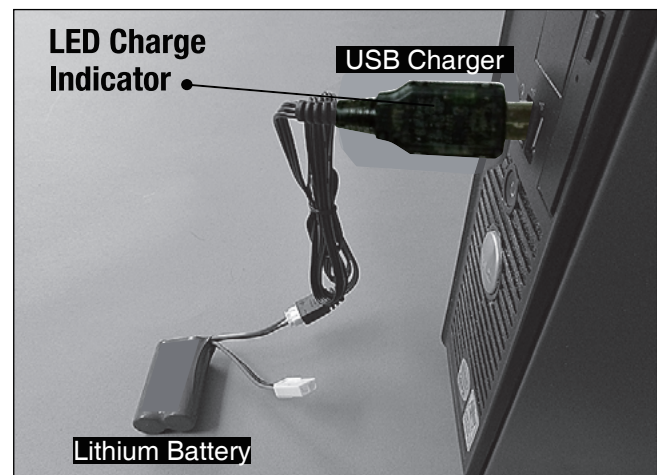

Troubleshooting Guide

Problem	Possible Cause	Solution
Boat does not respond to throttle but responds to other controls	Throttle servo travel is lower than 100%	Make sure throttle servo travel is 100% or greater
	Throttle channel is reversed	Reverse throttle channel on transmitter
Extra noise or extra vibration	Damaged propeller, shaft or motor	Replace damaged parts
	Propeller is out of balance	Balance or replace propeller
Reduced runtime or boat underpowered	Boat battery charge is low	Completely recharge battery
	Boat battery is damaged	Replace boat battery and follow battery instructions
	Blocking or friction on shaft or propeller	Disassemble, lubricate and correctly align parts
	Boat conditions may be too cold	Make sure battery is warm before use
	Battery capacity may be too low for conditions	Replace battery or use a larger capacity battery

Problem	Possible Cause	Solution
Reduced runtime or boat underpowered	Drive dog is too close	Loosen coupling at shaft and move away shaft a small amount
	Too little lubrication on shaft	Fully lubricate shaft
	Vegetation or other obstacles block the rudder or propeller	Remove boat from the water and obstacles
Boat does not bind (during binding) to transmitter	Transmitter is too near boat during binding process	Move powered transmitter a few feet from boat, disconnect and reconnect battery to boat
	Boat or transmitter is too close to large metal object	Move boat or transmitter away from large metal object
	Bind plug is not installed correctly	Install bind plug and bind boat to transmitter
	Boat battery/ Transmitter battery charge is too low	Replace/recharge batteries
	ESC switch is off	Power on ESC switch
Boat tends to dive in water or takes on water	The boat hull is not completely closed	Dry out the boat and ensure the hatch is fully closed on the hull before returning the boat to the water
	Center of gravity is too far forward	Move batteries back in the hull
	Trim tabs are angled incorrectly on the back of the boat	Angle each trim tab up a small amount to lift the bow or down a small amount to lower the bow
Boat tends to turn one direction	Rudder or rudder trim is not centered	Repair rudder or adjust rudder and rudder trim for straight running when control is at neutral
	Vertical fins of trim tabs are angled incorrectly	Angle the fins a small amount right or left so that the boat goes straight when the rudder is at neutral
Rudder does not move	Rudder, linkage or servo damage	Replace or repair damaged parts and adjust controls
	Wire is damaged or connections are loose	Do a check of wires and connections, connect or replace as needed
	Transmitter is not bound correctly or the incorrect boat was selected	Rebind or select correct boat in transmitter
	BEC (Battery Elimination Circuit) of the ESC is damaged	Replace ESC
	ESC switch is off	Power on ESC switch
Controls reversed	Transmitter settings are reversed	Do the Control Direction Test and adjust controls on transmitter appropriately
Motor or ESC overheats	Blocked water cooler tubes	Clean or replace water tubes

Transmitter Instruction

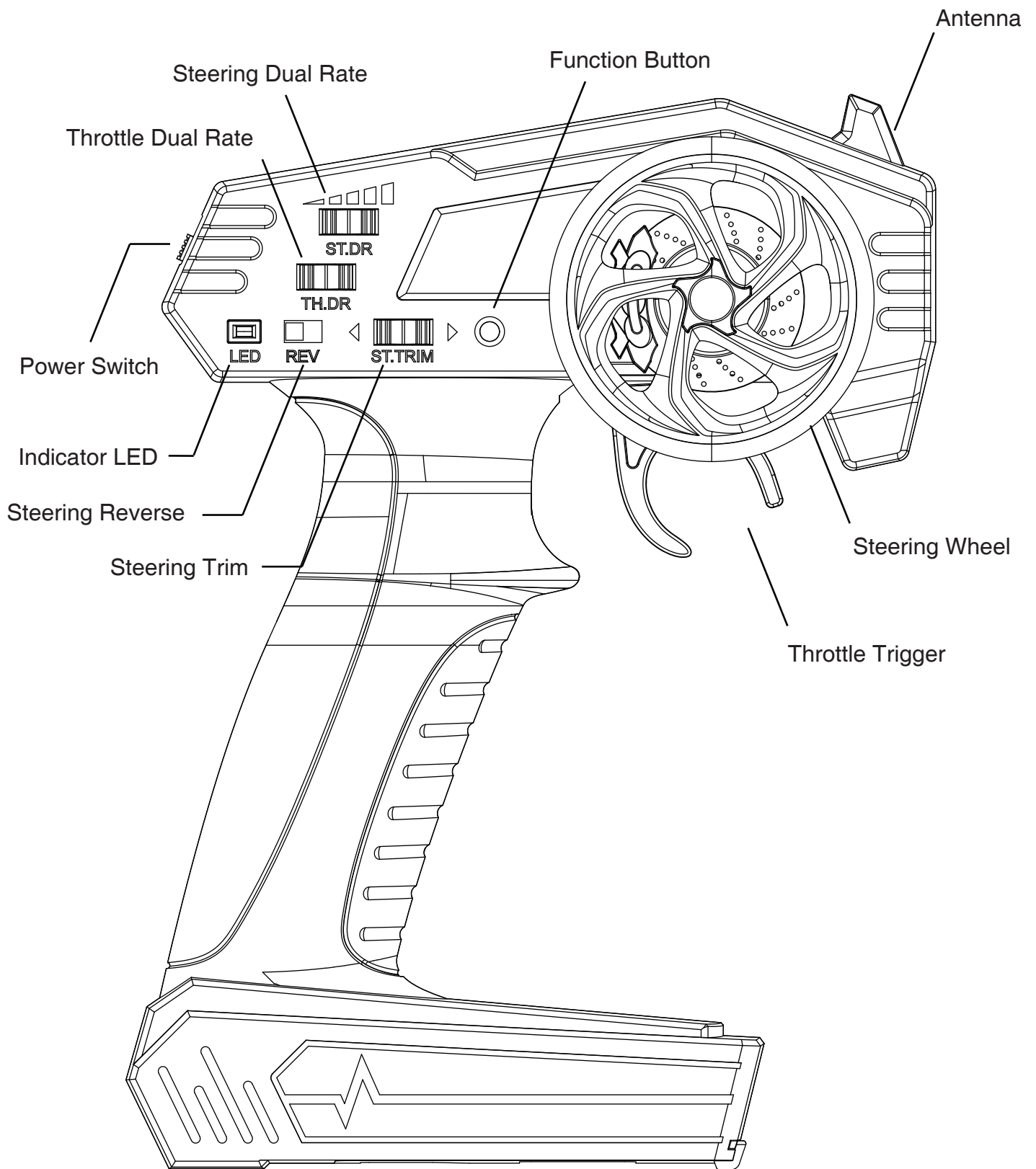

ON / OFF Switch

Slide the switch up to turn on the transmitter, switch down to turn off.

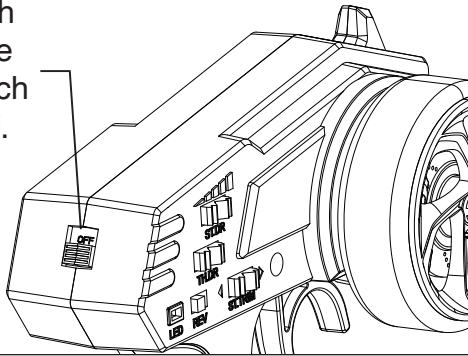

Battery LED Monitor

Solid red:
Battery is in good condition(above 4.3V).
Flashing red with beeping:
Battery is at low voltage. Replace batteries.

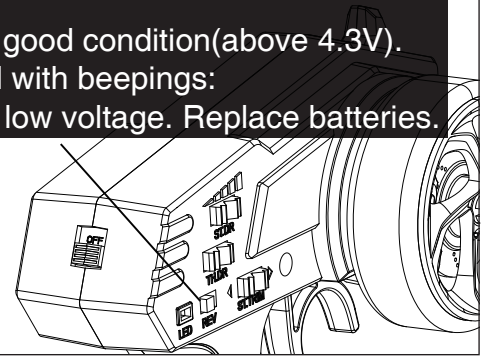

Dual Rate

Steering Dual Rate

Throttle Dual Rate

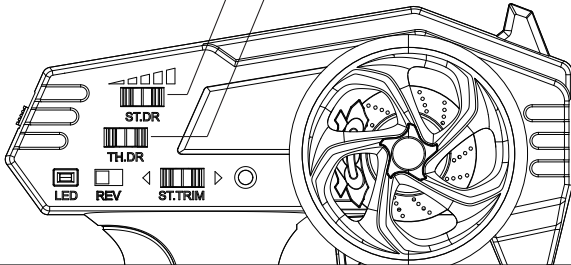

Adjust the steering dual rates to gain the proper steering ratio. Switch left / right to gain smaller / larger steering angle.

Adjust the throttle dual rates to adjust the top speed of throttle. It is initially set at 100% throttle, switch left to slow down the top speed.

Steering Reverse Switch

Steering Reverse Switch

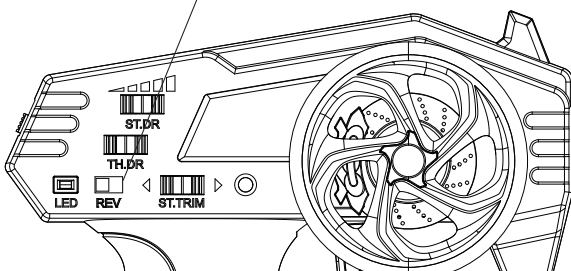

If the direction of the servo is wrong, slide the steering reverse switch to the opposite direction.

Steering Trim

Steering Trim

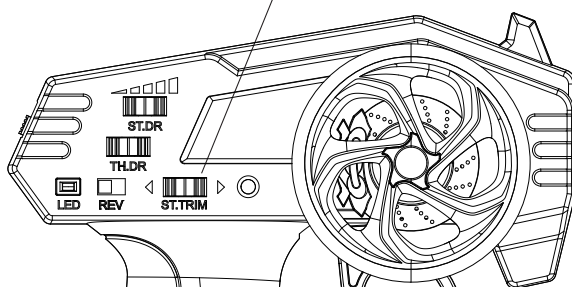

The steering trimmer is used to adjust the central position of servo if the vehicle can't run straightly. Switch left / right to adjust servo central position to left / right.

Receiver Connection and Binding

Binding is the process of programming the receiver to recognize the GUID (Globally Unique Identifier) code of a single specific transmitter. When a receiver is bound to a transmitter, the receiver will only respond to that specific transmitter. If you need to rebind for any reason, please follow these steps:

1. With the transmitter switched OFF.
2. Connect the boat battery to the receiver, then turn on the transmitter within 3 seconds.
3. The receiver LED will flash for 3-8 seconds to bind automatically.
4. After the receiver LED stop flashing, it means the binding is done.

Operation Instruction

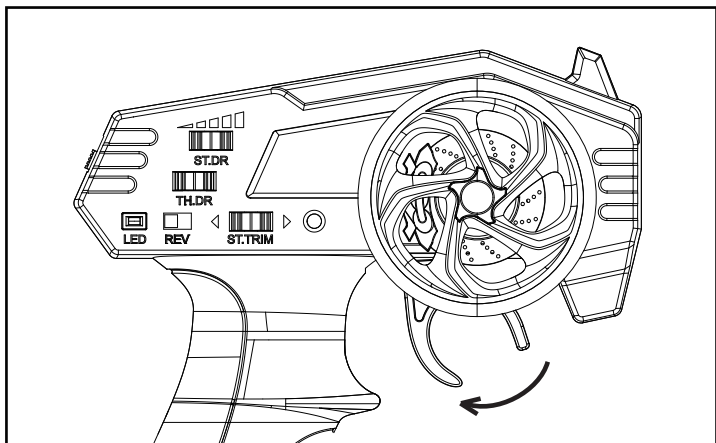

To move forward the boat, pull the throttle trigger as shown.

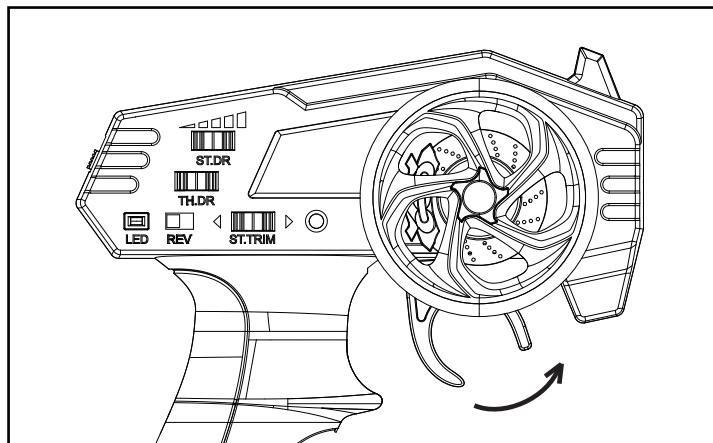

To move backward the boat (if with reverse function), push the throttle trigger as shown.

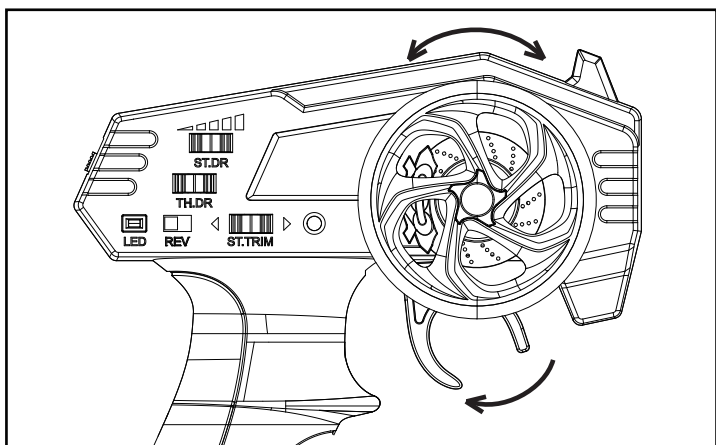

Rotate the steering wheel clockwise / counter-clockwise while pulling the trigger to make a right / left turn.

Function Button

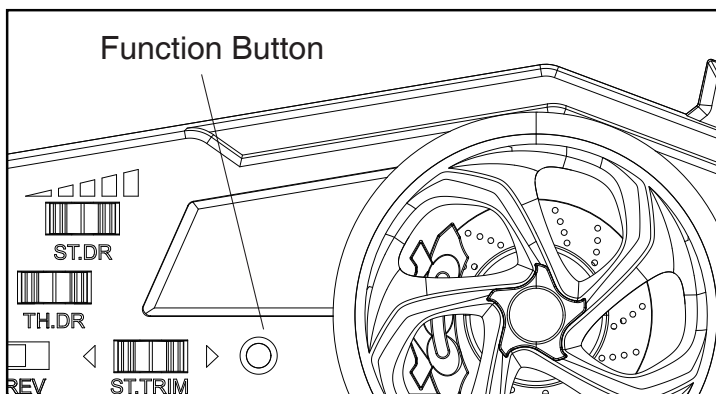

For the 797 series with LED, short press the button to turn on the LED. When the LED is on, each short press will switch LED colors, until it turns off. Double press the button to change LED modes (solid, blink).

For the 795 series with LED, short press the button to turn on/off the LED. Double short press to run in demo mode, the boat will run in certain track automatically.

Low Battery Alarm

When the boat battery is running at low power, the transmitter LED will flash with two beeping to alarm. You must collect back your boat and replace the battery with a full power one. Keep running with low power battery could cause accidents, such as boat missing, damaged, or unable to return.

Failsafe Alarm

When the boat running at edge of signal loss or out of range, the transmitter LED will flash with four beeping to alarm.

You must run your boat within a safe range, otherwise it could cause accidents, such as boat missing, damaged, or unable to return.